

GS15B single tube grounded screen 250W+ PA for 1296 MHz.

This PA is totally stable up to 300W output if operated with parameters below:

Anode voltage	=	1600 – 1800 Vdc
Anode current	=	<350mA
Screen voltage	=	320 – 350 Vdc
Screen current	=	+ 1 to -1mA when tuned correctly.
Grid voltage	=	-22 to -32 Vdc
Grid current	=	5-20mA
Idle current	=	50-75mA
Heater voltage	=	5.5 – 5.8 Vac
Drive power	=	10W
Typical efficiency	=	50%

This PA can produce up to 400W with minor thermal drift in class B or C, if operated with parameters below:

Anode voltage	=	2200 – 2300 Vdc
Anode current	=	<325mA
Screen voltage	=	350 Vdc
Screen current	=	+ 1 to -1mA when tuned correctly.
Grid voltage	=	30 to -40 Vdc
Grid current	=	8-15mA
Idle current	=	0mA
Heater voltage	=	5.5 – 5.8 Vac
Drive power	=	15W
Typical efficiency	=	>55%

A few warnings:

Since this tube is generating negative screen current, it will self supply screen voltage. There **MUST** be a resistor of <100KOhm between ground and cathode at all times to bleed of self generated screen voltage.

NEVER switch the screen voltage on and off without this resistor in place to bleed of the screen voltage.

Disconnecting the screen with anode voltage present and no load resistance **WILL** cause a failure.

The result is that the screen voltage will increase up to the anode voltage potential and cause an arc-over in the grid de-coupling insulator or internal arc in the tube.

The screen power supply **must** be of shunt type to prevent a screen voltage increase when the amplifier is tuned in-correctly, or you could get an anode current run-away.
It is also recommended to use a sensing circuit to trip to amp if the screen current goes more than 5-10 mA negative.

Tuning:

Keep eyes on the screen current while tuning the PA. The screen current will go drastically negative (-15mA) if the cavity is tuned too low in frequency.

Apply 5-10W drive and tune the output for maximum power by alternately adjust the anode tuner and rotate the output coupling loop. Tune the input cavity for best SWR by alternately rotate the tuner and adjust the input coupler in and out.

Re-adjust the output for maximum power. Watch the screen current and adjust the anode tuner slowly CW until you see a decrease of about 1mA (negative current). You should now be about 10W below maximum power. This will ensure that the amp will reach full power immediately after an idle period.

Cooling:

Use a distilled-water cooling-system with good flow rate. It should be able to handle >300W load without over-heating.

It is recommended to use a small quiet muffin-fan to blow on the input cavity. The amp is generating very little heat so a low capacity fan is sufficient.

Heater voltage:

Too high heater voltage will drastically shorten the tube life.

Recommended fine-tuning:

1. Run the heater on 6 volts for 10 minutes or more.
2. Drive the amp to 100-200W output.
3. Lower the heater voltage in 0.1V steps until the output starts to drop. Wait a few minutes between each step. This typically happens at 5.5 to 5.8 volt.
4. Increase the heater voltage to 0.2 volt above the point where the output drops.

This is done to minimize any cathode back-heating. Tests have shown that many tubes have full emission down to 5.4 volts. Higher heater voltage than necessary will only shorten the tube life with NO power gain.

Leave the heater on for at least 2 minutes before transmitting to allow the cathode surface to reach uniform temperature.

Tube replacement:

The cavity top has to be removed to replace the tube.

1. Remove the 8 outer screws.
2. Pull off the top plate.
3. Pull out the tube.
4. Install the new tube. Push down until it bottoms out.
5. Push the top plate in place. The plate has a hole that must match the roll-pin in the cavity.
6. Install all screws.
7. Re-tune the cavity to match the new tube.

Rf-Chokes:

All de-coupling is done inside the amp and no external rf-chokes are needed.





RF-Leaks:

The cavity's RF leaks are almost zero so no extra shielding is needed for this reason.

You are working with lethal voltages, so install in a cabinet or other place where the high voltage can not be reached.

Good luck

GS-15B - S Ver 2.1-125
23cm 250W+ Amp
Scale 1:1

Material Color Code	
	Brass
	Steel
	Stainless
	Copper
	Copper

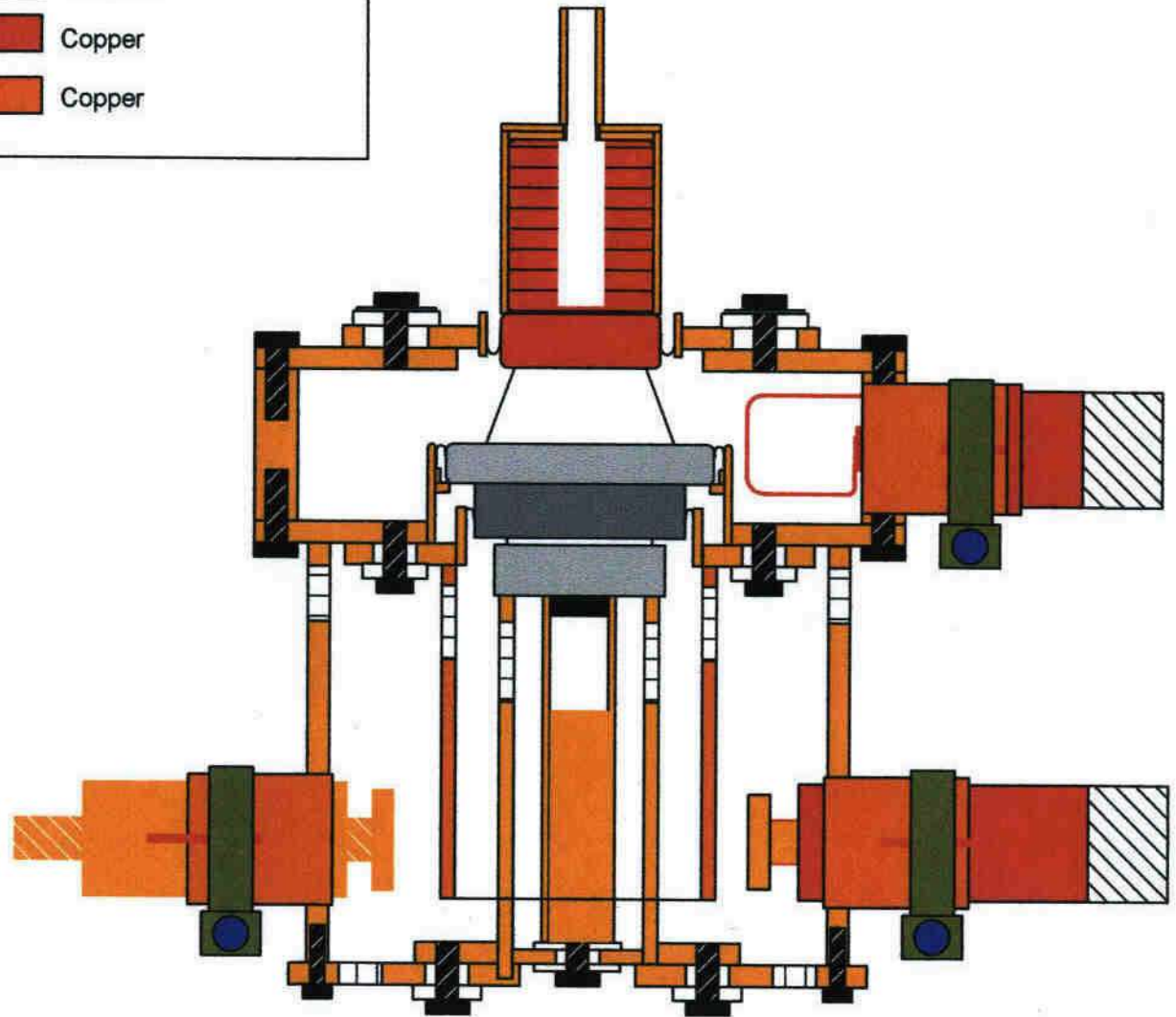
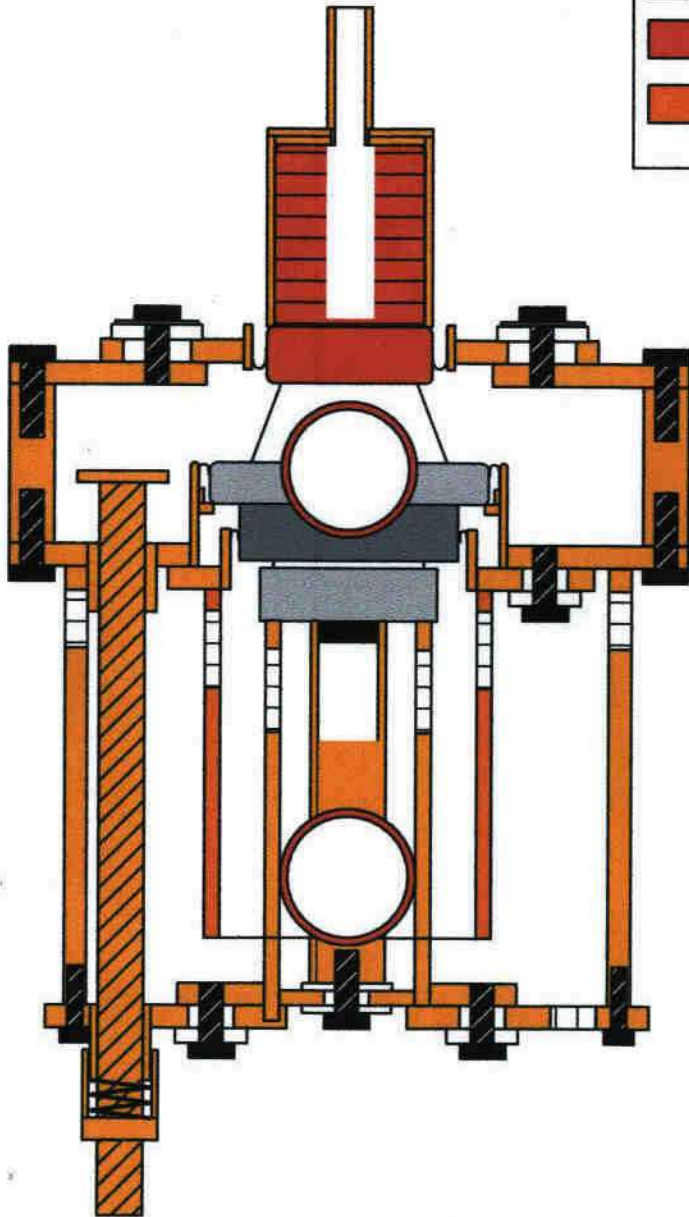

Test Report

7

Plate insulator test voltage =	3000V	OK
Grid insulator test voltage =	1000V	OK
Cathode resonator test voltage =	1000V	OK
Plate insulator capacitance =	475	pF
Grid insulator capacitance =	326	pF
Cathode insulator capacitance =	288	pF

Test Conditions:

Heater voltage	=	5.8	V
Plate voltage	=	1800	V
Screen voltage	=	350	V
Grid voltage	=	-29	V
Idle current	=	75	mA
Drive power	=	10	W
Plate current	=	345	mA
Screen current	=	1	mA
Grid current	=	18	mA
Output	=	300	W

Grounded screen tetrode connection diagram

